



Manual

www.philippi-online.de

philippi elektrische systeme gmbh
Neckaraue 19
D-71686 Remseck am Neckar

Phone: +49 (0)7146/8744-0
Telefax: +49 (0)7146/8744-22
E-mail: info@philippi-online.de

Safety

- no change in the equipment may be made, otherwise the CE indication expires
- the connection of the distribution circuit may only by electrical specialists be made.
- before the connection of the distribution circuit the battery inlets are to be clamped. To the correct polarity of the batteries pay attention!
- the automatic circuit breakers built in the distribution circuits serve for securing the inlets for the consumers. The security of the attached consumers takes place via the safety devices built in the devices.

The assembly and operating instruction are a component of the component supply. It must importantly for later maintenance work - well to be kept and to possible subsequent owners of the distribution circuit be passed on.

Non-liability

both the adherence to the operating instruction, and the conditions and methods when installation, enterprise, using and maintenance the distribution circuit cannot be supervised of philippi elektrische systeme. Therefore we do not take any responsibility and adhesion for losses, damage or costs, which develop themselves from incorrect installation and inappropriate enterprise.

Warranty

we carry out due to our "general trading conditions" warranty for the supplied distribution circuits. These trading conditions are basis of all sales and delivery offers, them are printed and attached to all offers and confirmation of orders in our catalogs.

CE-Mark



this equipment fulfills the requirements of the European Union:

89/336/EWG "Elektromagnetische Verträglichkeit"

The conformity of the equipment is confirmed by the CE mark.

Introduction

distribution panels series STV are for distributing and securing the electrical 12/24V-system. On the front plate are the protective switches, control and display elements. Each individual electric circuit is equipped with switchable automatic circuit breakers and trip-free release. The light-emitting diode display announces whether the appropriate electric circuit switched on and is ready for use. Some models are equipped with additional battery voltage announcements. The additional current announcements inform about the up-to-date flowing discharge current. The individual electric circuits are marked on the front side with the enclosed circuit labels by gluing on into the fields planned for it. The protective switches are suitable for battery voltages by 12V and/or 24V without modifications be made must.

Scope of supply

Power distribution panel

Manual

1 set of self adhesive labels

Spare parts

self adhesive labels (1set)

Stack connectors 6,3mm -2,5mm²

circuit breaker 1-pole.

circuit breaker 2-pole.

SKZ-D, SKZ-GB, SKZ-NL

FSH 6,3/1,5-2,5

3130-F11B-H7T1-W29AG-10A (6..20A)

3130-F15B-H7T1-W29AG-10A (6..20A)

Technical Datas

Dimensions

see cataloge

Rated voltage

DC 10-28V

Fuse size

10 A (Standard), alternative 6, 16, 20 A

Panel

Aluminium grey coloured

Installation

for the assembly well accessible places are suitable inside the boat; usually at the chart table. The rear area should possess at least one depth of 15 cm, in order to be able to implement the wiring carefully and clearly and thus surely. It is advisable to insert the instrument panel in such a way that it is accessible for extensions, changes and possible repairs later also again from the rear.

For the installation a cutout of small 10mm per side edge of the instrument panel dimensions is to be planned. To the four mounting holes the instrument panel can be fastened with screws of your choice.

Warning

high currents can with to thin lines or transition resistances by contacts corroded to overheated lines or connections lead, which can catch fire. Consider therefore the printed cable diameter table and pay attention you to sorgfaelig implemented connections and firm connection.

Connection

the pre wired red inlet cables (+) 6mm² are attached to the positive terminal of the service battery. When extending the cable diameter of the inlet installed at the distribution circuit may not be fallen below fire risk!

The inlet must be attached at the battery over an interposed high current safety device dimensioned correctly to the inlet cross section.

The consumer outlet lines become at Steck-bzw. Screwing contacts of the automatic circuit breakers attached.

The blue negative conductor (-) is attached to the negative pole of the battery. It serves the light-emitting diode display for the supply and with presence of a voltmeter as absolute dimensions.

Overloading

in the case of overloading or short-circuit of an electric circuit is switched off the attached consumers by releasing the automatic circuit breaker and the light-emitting diode display expires. After the overloading condition is waived can the respective automatic circuit breaker by restarting again be reset.

Connection to the battery

Fuse size max. 35A bei 6 mm²-wire

Fuse size max. 50A bei 10 mm²-wire

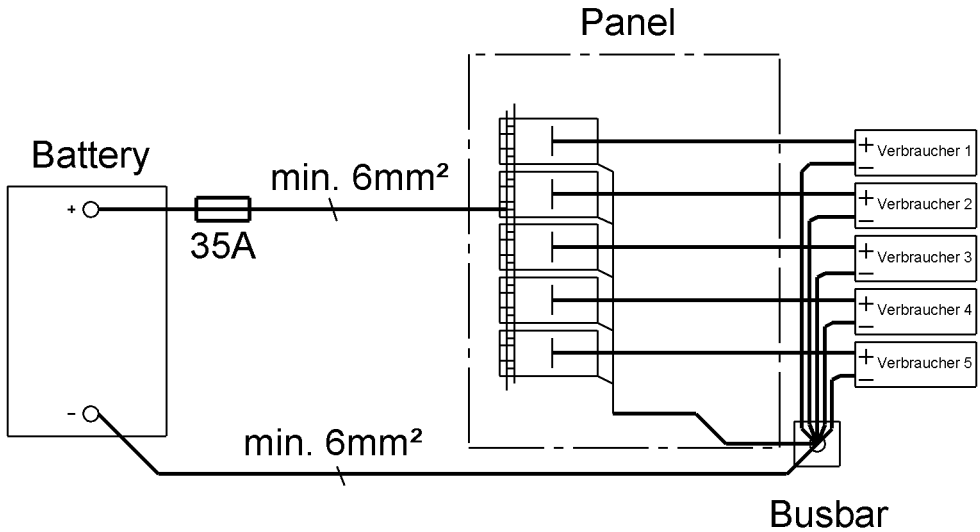

Connection of the Instruments

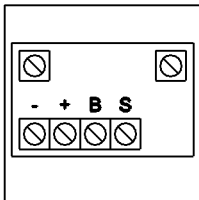

- : Minus Battery
- + : Power supply 12/24V
- B : Illumination 12/24V
- S : Sensor for tank (10-180 Ohm)

Connection of the Position lights control

Positionslampenkontrolle POS-EL 50

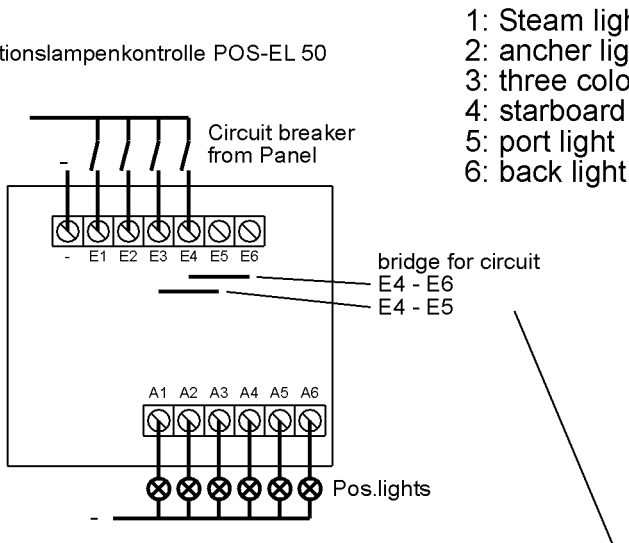

Standard the circuits 4, 5, 6 are connected to each other, this means with one switch the back-, starboard and port light are switched together. The monitoring takes place for each individual circuit. To change the combined switching, please remove the bridges.

Connection of the control switches

Needed switches:

Voltmeter-switch over: 1-0-2	Best.-Nr. 5 1808 1103
Tankgeber-switch over: 1-2	Best.-Nr. 5 1803 1102
illumination switch 0-1	Best.-Nr. 5 1801 1102
Batt.-main switch FBH: 1-0-2	Best.-Nr. 5 1808 1302
Bilge Auto-Man. switch 1-0-2	Best.-Nr. 5 1808 1103
Tankalarm switch 0-1	Best.-Nr. 5 1801 1102
Tankalarm 2times over: 1-0-2	Best.-Nr. 5 1808 1103

Connection of the instruments

view is from the back side of the panel

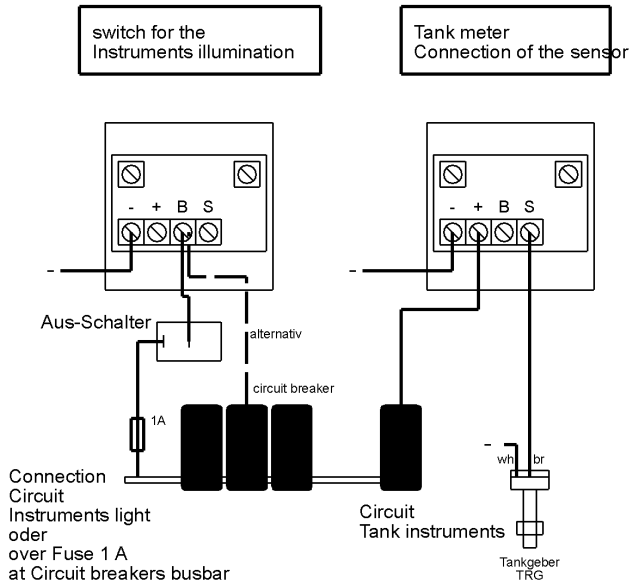

VOLTMETER:
Voltmeter with switch over
for measuring lines

tank instrument
switch over
for 2 sensors

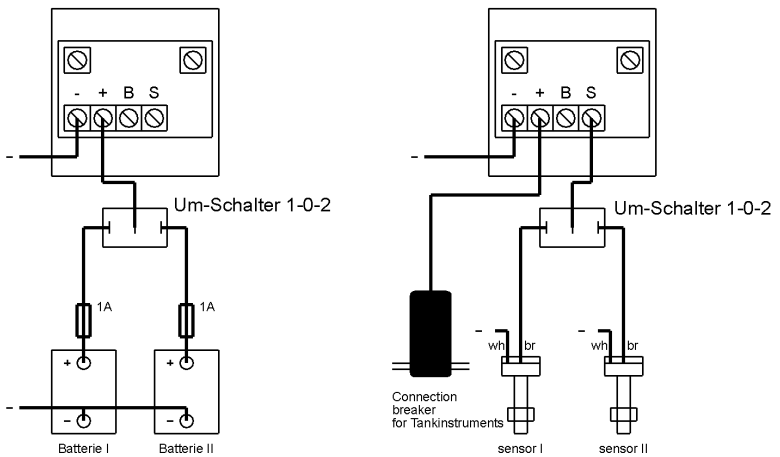

measuring lines please fuse direkt at the battery !

Further connection examples for control switches

Switch for Battery main switch FBH

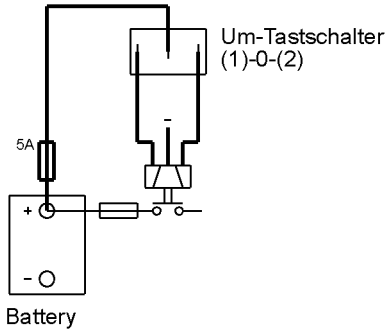

AUTO-MAN-switch over for autom. Bilgenpump

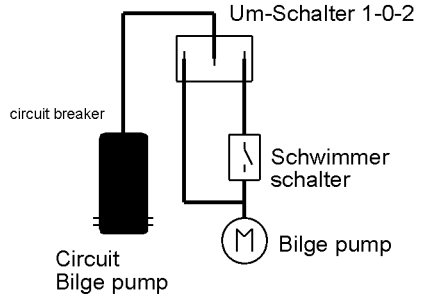

ALARM-ON/OFF-switch for Tanksensor TRG

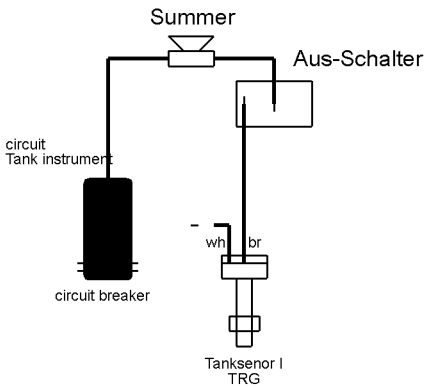

ALARM-ON/OFF-switch for 2x Tanksensor TRG

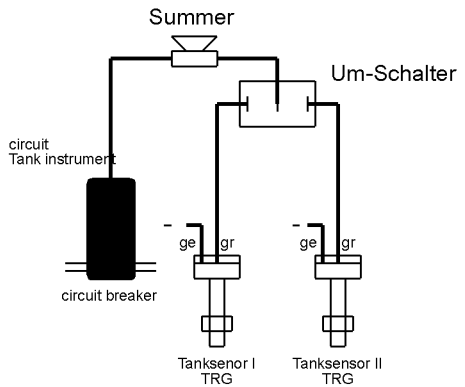

Ammeter connection

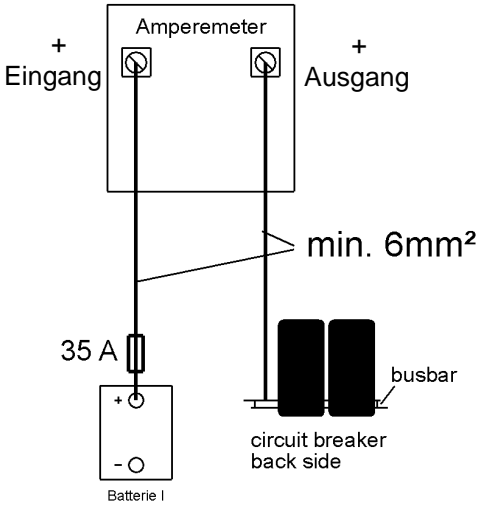

Remote control for deep discharge protector TS 12/15

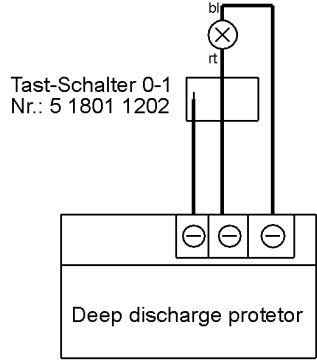

Ammeter with external Shunt

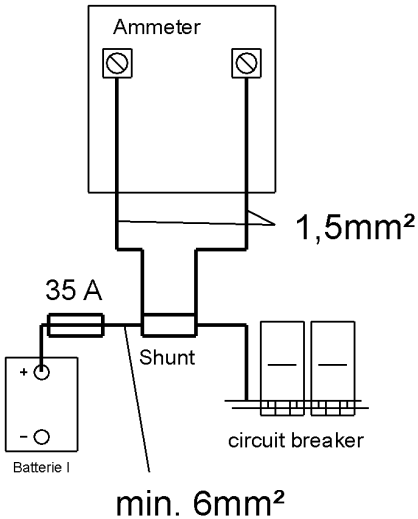

Remote control for deep discharge protector TSA 12/15

